

77MB TRADING CARD (ROM)

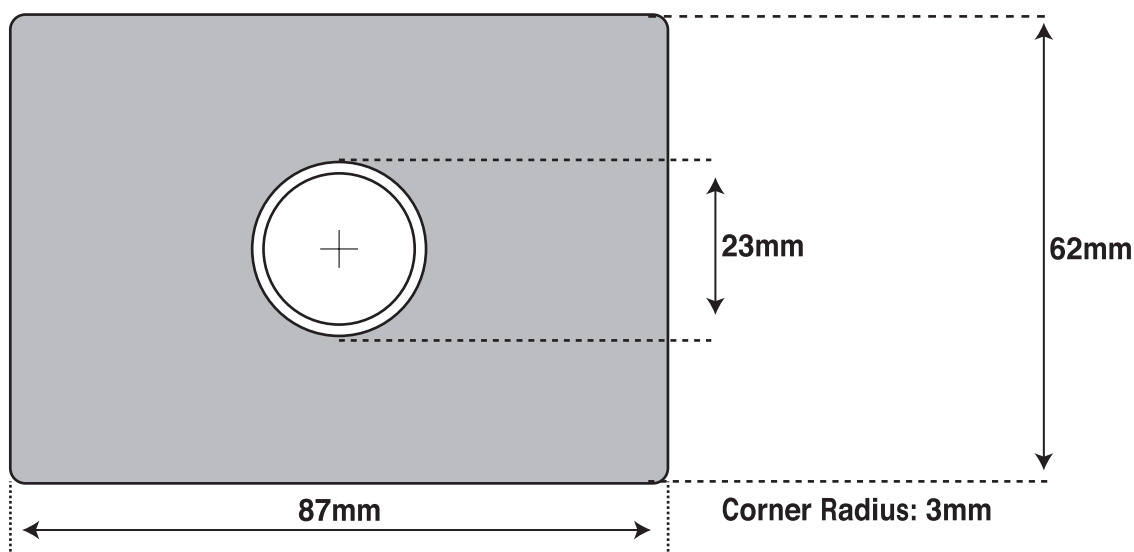

printable area



SPOT PRINTING - UP TO 5 COLOURS...

Film if Supplied :: Right Reading, Positive Emulsion UP
Recommended Minimum Type Size :: 6pt
Registration Marks :: Placed at least 5mm Outside ROM area
Keylines :: Remove all Keylines

HALF TONE PRINTING...

Screen Ruling :: 85/100 lines per inch
Dot Shape :: Elliptical
Dot Density Range :: 12% - 90%
Screen Angles :: 45° Monotone,
75° Duotone, 15° Tripletone

Solid areas where possible, need to be placed on separate film as the viscosity of the ink for half tone and solid areas is different.

PROCESS PRINTING...

Screen Ruling :: 100/110 or 133 lines per inch
Dot Shape :: Elliptical
Dot Density Range :: 12% - 90%
Screen Angles :: Cyan 75°, Magenta 45°
Yellow 0°, Black 15°

Avoid Printing Large Solid Areas when Using 4 Colour Process

Digital Formats...

Mac or PC eps files, Quark Xpress 4.1, Illustrator eps, Photoshop jpeg or tiff files are the preferred formats

Saving your artwork...

Artwork should be supplied on CD or Zip disk
Files can be supplied via e-mail
Attachments that are compressed using Stuffit or Winzip which will reduce the file size

Before you send your file...

Check that all typefaces are included with the document on the disc
Ensure all fonts within eps or pdf are embedded or have been converted to paths
Include all graphics and images used in the document
Use CMYK not LAB or RGB colour models